

Requirements for Construction of Monuments



Cemeteries

| Cemetery | Location | Type of Cemetery |
|----------|-----------------------------------|---|
| Minmi | Minmi Road, Minmi | Monumental |
| Stockton | Fullerton Street, Stockton | Monumental, Lawn Beam |
| Wallsend | Sandgate Road, Birmingham Gardens | Monumental, Lawn Beam, Niche Wall and Memorial Garden |

All work proposed to a grave site is subject to prior approval of the City of Newcastle (Council). All monuments in Council cemeteries must be installed through companies with a current Permit to Work in Council cemeteries (see over). Applications are made by completion of the Application for Monumental Works and relevant fees and charges forwarded to Council for approval **prior to any work commencing on site.**

Please note: detailed drawings, including dimensions are to accompany Application for Monumental Works.

On receipt of the Application, a check is made to ensure construction will be in accordance with the Australian Standard, AS 4020-1994 (Headstones and Cemetery Monuments) and the City of Newcastle's Requirements for the Construction of Monuments.

Guidelines

A monument may be installed 3 months after the burial.

Approval;

- *Living Burial Licence owner*; Council will only grant monument approval with the consent of the holder of the Burial Licence, ie. Grantee.
- *Deceased Burial Licence owner*; should the Burial Licence holder decease, then the Burial Licence becomes part of his / her estate, to be administered by his / her Executor. If there is no Executor, then the Next of Kin becomes the holder of the Burial Licence. Documentation must accompany Application for Monumental Works to establish line of control. If a Will is not available or Council does not hold record showing Burial Licence

ownership, the Application must be accompanied by a Statutory Declaration that the Applicant is the next of kin of the deceased Burial Licence holder, or has the consent of all available direct descendants with whom contact has been possible.

Unauthorised kerbing / edging of any description including concrete, timber, treated logs, ferrous material, bricks or stones **cannot** be placed around or in the perimeter of the grave. This may be removed to for worker safety to assist site access for maintenance or burials.

Flowers may only be placed in the containers that form part of the monument.

The placing of glass / containers, vases or jars inside the cemetery boundary is prohibited. Plants, trees, shrubs and potted plants are prohibited in / on or around the grave site. Ornaments, grave filling such as bark chips, stones or gravel are prohibited on / in or around the grave and maybe removed to assist access to the site.

Ornamental flowers placed on the lawn surface may be removed to assist with mowing or to access other areas of the site for further burials.

Council reserves the right to remove without notice;

- any unauthorised works.
- unapproved, excessive tributes or incorrectly located flower containers.

Council will not be liable for the future care, maintenance, preservation, conservation or restoration of the construction (headstone and surrounds) erected or placed over the grave.

Where a grave is to be re-opened for a second interment any monumental work that must be removed to allow that interment is to be arranged by the funeral director on behalf of the family or person arranging the funeral. Council under no circumstances is responsible for the removal of monumental work.

Monumental work is to be removed to allow Council reasonable time to prepare the grave plot for burial. The funeral director is to ensure that any monumental work removed for a funeral is replaced within 48 hours of the funeral.

All graves and monuments over fifty (50) years and older are subject to the Heritage Act. It is the responsibility of the applicant and grantee to ensure that the proposed work is consistent with the requirements of the Act.

Specifications

All work to be consistent with Australian Standard, AS 4020-1994 (Headstones and Cemetery Monuments) as a minimum and the City of Newcastle's Requirements for the Construction of Monuments.

Monumental Sections

Piers: Full Monument

- Requires minimum depth of 1800 (below footing level) and 200 wide (head and foot) and 150 wide (middle). NB. for single depth graves, minimum depth of 1400.
- Requires minimum of 6 piers.

Piers: Headstone Only

- Requires minimum depth of 1800 (below footing level) and 200. NB. for single depth graves, minimum depth of 1400.
- Requires minimum of 2 piers.

Base / Footing: Headstone Only

- Maximum depth permitted 350.

Application for Monumental Works must also show;

- Bars centrally placed in each pier and confirmation of material type, ie. galvanised steel.
- Pinning of headstone to base / footing.

Lawn Beam Sections

The headstone must be installed on the concrete beam.

The headstone can have the option of up to two flower containers of the same product as the headstone.

The headstone can be of a recumbent 'desk' style affixed to the beam or an upright headstone set on a base (1150mm maximum length x 300mm maximum depth) affixed to the beam with a maximum height of 750mm above the beam (including base).

**Drawing not to scale*

H: 750mm maximum

D: 300mm maximum

H: 100mm maximum

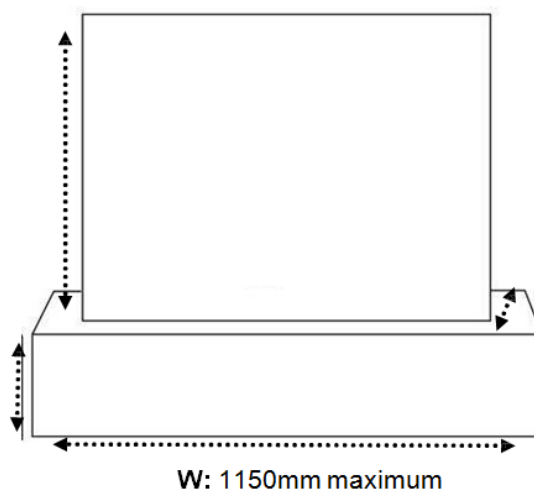

Construction of Monuments: Companies with Current Permit to Work in Council Cemeteries

| Name | Mobile | Email |
|---|--------------|----------------------------------|
| BB Memorials and Cemetery Services | 0407 220623 | bellbrad@bigpond.net.au |
| Budget Headstones | 0479 031705 | info@budgetheadstones.com.au |
| Delic and Company | 0404 831641 | delicandco@bigpond.com |
| Edstein Creative Stone | 02 4968 3600 | allend@edstein.com.au |
| L.S.Apthorpe and Family Funeral Directors | 02 4937 5348 | apthorpeadmin@bigpond.com |
| Mediterranean Stone | 02 4943 8471 | mail@mediterraneanstone.com.au |
| S. R. Horder, Monumental Masons | 02 4937 6233 | sales@srhorder.com.au |
| Partridge Bros | 02 6572 2917 | service@partridgebrothers.com.au |